



# OPTIPARTS

MARINE EQUIPMENT

2010



20 Years ago the company Optiparts Marine Equipment was founded. Since that time we have continuously developed our range of products for the Optimist dinghy. For some years now we have been able to claim that we are the leading supplier of Optimist spars, fittings and accessories. We also produce several accessories for Laser®, 420 and other dinghies under the trade name Windesign®.

OPTIPARTS has its own display, promotion material and leaflets which are available upon request.

For availability look at [www.optiparts.com](http://www.optiparts.com) or [www.windesign.eu](http://www.windesign.eu)

Our extensive range of products is exported to more than 80 countries around the world.

The names Optiparts® and Windesign® are registered trade marks.

## ACCESSORIES FOR OPTIMIST'S: PAGE

BLADE BAG	5
BLOCKS	9/10
BOW BUMPER	2
BUOYANCY BAGS	7
CLEATS	11
COVERS	4
DAGGERBOARD PROTECTION	5
DECK COLLARS, MAST SLEEVE	7
DVD AND CD	11/18
END FITTINGS	8
EYE STRAPS	11
FOILS	5
GRIPS	16
HANDBAILERS	12
HIKINGPANTS	13
HIKING STRAPS	12
HIKING BENCH	11/18
HOOK-IN BLOCKS	10
KEY RING OPTI	12
LINES	9
MAINSHEET	10
MASTLOCK	6
MAST STEPS	6
MINISAIL	12
OPTIMIST MODEL	12
PADDLES	12
PROTEST FLAG	9
RATCHET BLOCKS	9
ROOF RACK COVERS	15
ROWING SEAT	7
RUDDER FITTINGS	6
SAILBAGS	3
SAILBATTENS	3
SAILNUMBERS	3
SAILS	3
SHACKLES	10
SPAR ACCESSORIES	8
SPARS	1/2
SPRIT HALYARDS	10
TELLTALES	3
TILLER EXTENSIONS	6/16
TILLERS	6
TOESTRAPS	12
TROLLIES / DOLLIES	4
WEBBING	12
WIND INDICATORS	8

## WINDESIGN SAILING GEAR:

BAGS	14
BOOTS, NEOPRENE	13
BUOYANCY AID	13
GLASSES	15
GLOVES	14
MASTFLOAT	16
HIKINGPANTS	13
RACING RULES DVD	11
SPRAY TOP	13
TIMER	15
TRAPEZE HARNESS	14
WATCHES	15

## ACCESSORIES FOR 420'S 17 / 18

## ACCESSORIES FOR LASER® 18 / 19 / 20 / 21

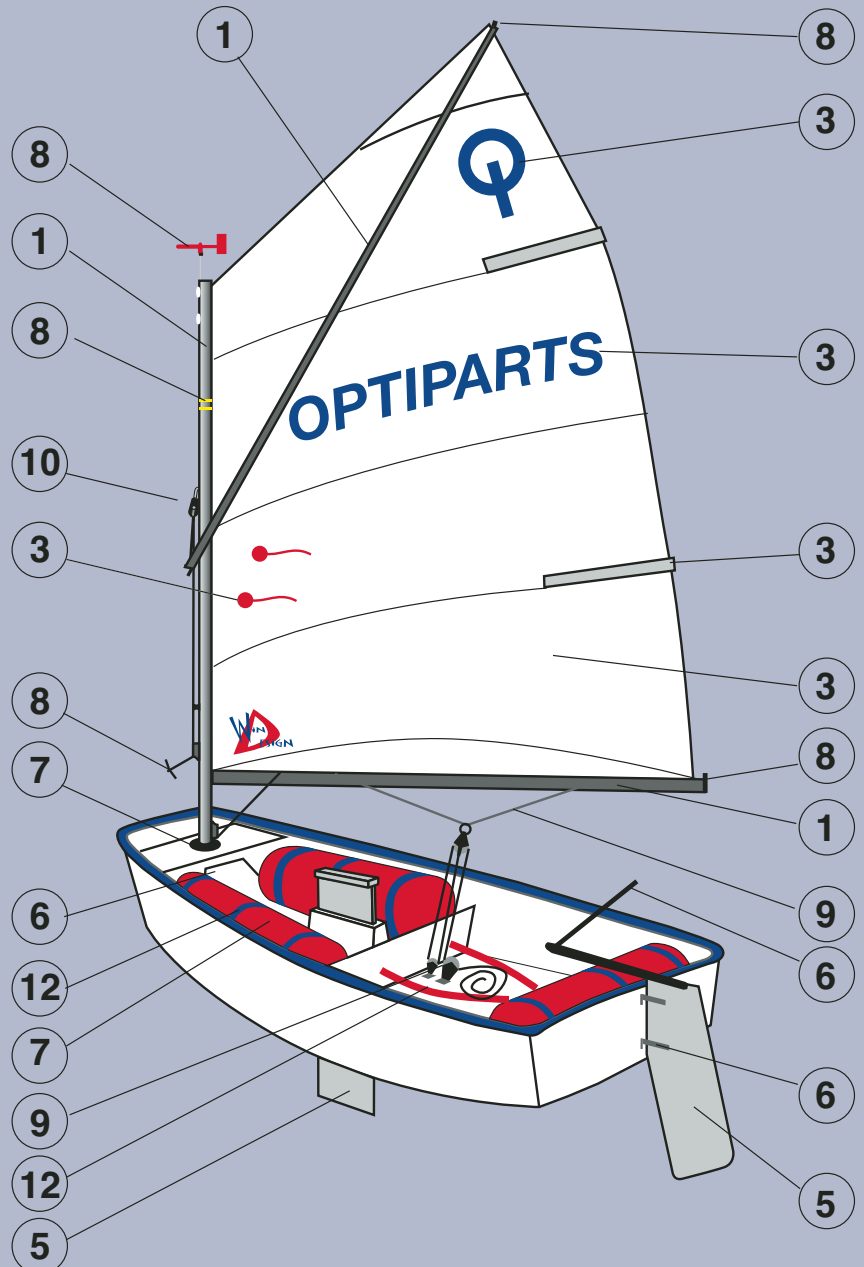

### Cover photo credits:

Matias Capizzano, [www.capizzano.com](http://www.capizzano.com)

Laser® is a registered trademark of Velum limited and Performance Sailcraft Australia ltd

## BLACKGOLD RACING SPARS

The BLACKGOLD RIG is the world's most advanced Optimist rig. For many years it has been chosen as the official charter rig for the I.O.D.A World, European, Asian and Oceanian Championships. Several outstanding results have been achieved in the past years. A lot of credit goes to all the coaches, trainers and sailors with whom we developed this ultimate rig for Optimist racing.

Feature for feature, there is no equal to the Optiparts BLACKGOLD set. 45 microns Black hard anodized 7075 mast, a choice of 3 black anodized booms and a black anodized 7075 sprit. All black fittings, hard anodized cleats, a black sprit chafe guard, captive eye straps on the boom, a halyard cleat with becket. Zero stretch, zero creep, black, Vectran line package, 45 mm power boom, HARKEN ball bearing halyard blocks and pure Vectran spliced halyards.

ADVANTAGES : over spars from other mast makers

- Heavy duty Black hard anodized 7075 T6 mast.
- Aerospace spec. alloy super stiff 7075 T6 mast and sprit section.
- High Delrin heel plug, for less friction and to avoid wear.
- Stainless steel hook-in block backing plate - to avoid wear.
- Through bolted and insulated vang cleat - to prevent failure.
- Aluminum pin stop instead of plastic - to avoid breakage.
- Aluminum pennant holders - which do not cut the lines.
- Halyard with HARKEN hook-in block and 29 mm HARKEN Tielite block
- Pure Vectran spliced halyard.
- Low friction nylon wind indicator - extra sensitive.
- Delrin pin type heel-plug - no wear.
- Vectran control lines - zero stretch, zero creep - the ultimate
- Sprit adjuster handle

Unlike any other Optimist spar manufacturer we offer a choice of 4 booms : The 32 mm **BLACKLITE** bendy boom. It will depower the sail which enables the lightweight sailor to go faster in more wind.

The 40 mm **BLACKGOLD MEDIUM** boom. A stiff and lightweight boom which is suitable for the majority of sailors.

The 45 mm **BLACKGOLD POWER** boom. Stiffer to keep more tension on the leech for the heavier sailor.

The smaller bridle gives more space when tacking.

The 55 mm **BLACKMAX** boom

The ultra stiff and yet lightweight boom can be used without a bridle. This enables the larger sailor to land further forward when tacking.

All booms are made from high grade, tempered tube. Fitted with captive eye straps, black nylon in- and outboard end fittings, nylon outhaul cleat, 4 mm Vectran outhaul and bridle, Vectran/wire vang and outhaul trim gauge.

The 29 mm Blackmax racing sprit introduced last year has now been upgraded with new sprit ends. This sprit is 19% stiffer than the 27 mm Blackgold sprit.

It gives more control over the leech of the sail and is especially recommended for sailors over 45 kg.

EX900	BLACKGOLD mast. With rigging pack.
EX932	BLACKLITE 32 mm boom complete.
EX940	BLACKGOLD MEDIUM 40 mm boom complete.
EX945	BLACKGOLD POWER 45 mm boom complete.
EX955	BLACKMAX 55 mm boom complete.
EX960	BLACKGOLD 27 mm sprit.
EX965	BLACKMAX 29 mm sprit.
EX970	BLACKLITE set (EX900, EX932, EX960, EX13591)
EX975	BLACKGOLD MEDIUM set (EX900, EX940, EX960, EX13591)
EX978	BLACKGOLD POWER set (EX900, EX945, EX965, EX13591)
EX980	BLACKMAX set (EX900, EX955, EX965, EX13591)
EX13591	Rigging pack as with all BLACKGOLD sets

**BLACK GOLD**  
THE WORLDS MOST ADVANCED  
OPTIMIST RACING MAST

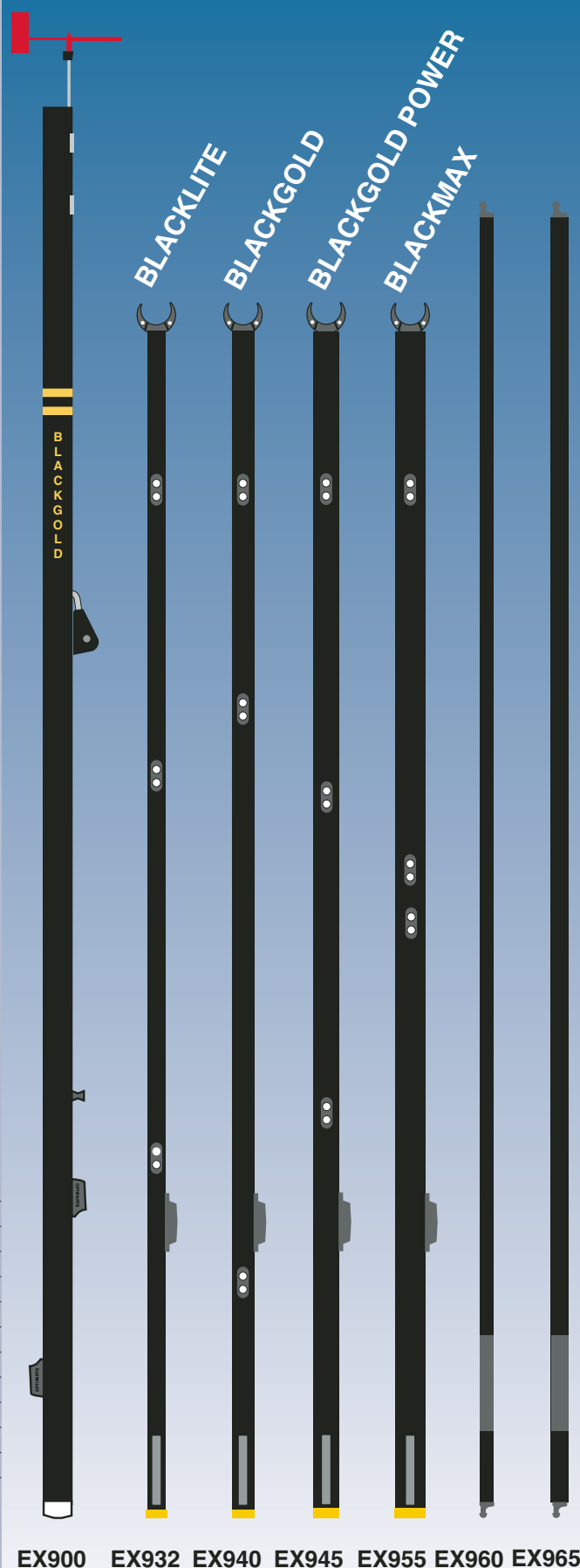

EX900 EX932 EX940 EX945 EX955 EX960 EX965

## SILVER REGATTA SPARS

Less stiff than Blackgold and ideal for light weight sailors who just started racing. The SILVER mast, boom and sprit are made of high quality aluminum tube. The lightweight 40 mm SILVER boom is much stiffer than the school boom and will allow the sailor to put more tension on the leach. The  $\varnothing$  25.4 mm SILVER sprit has 15 cm anti chafe protection tubing.

The Optiparts Silver set has the following features :

- Stainless steel hook-in block backing plate
- 2 special top pins
- Low friction wind indicator
- Aluminum halyard and downhaul Clamcleat
- Hook-in block with aluminum sheave in a nylon casing
- Line package with, 2 to 1, 4 mm Vectran halyard, 3 mm Dyneema bridle with ring, Dyneema outhaul, Spliced Vectran / 6 mm Dyneema downhaul

EX1005	SILVER regatta mast with rigging pack.
EX1022	SILVER 40 mm regatta boom complete.
EX1041	SILVER regatta sprit.
EX1048	SILVER regatta set with rigging pack.

## SCHOOL SPARS

3 configurations : Upgraded school, School and Sleeve school spars.

All consist of a  $\varnothing$  45 mm mast,  $\varnothing$  31 mm boom and  $\varnothing$  25.4 mm sprit made of high quality aluminum tube .

The UPGRADED mast is fitted with a stainless steel halyard block, aluminum Clamcleats, a nylon pin stop and two stainless steel eyes for fixing the head of the sail. The UPGRADED boom has blue nylon in- and out-board end fittings, a nylon outhaul cleat and nylon fittings for mainsheet and downhaul attachment. The UPGRADED sprit has blue sprit ends and 15 cm black tubing for protecting damage between the mast and the sprit.

EX1011	Upgraded School mast.
EX1031	Upgraded School boom.
EX1042	Upgraded School sprit.
EX1051	Upgraded School set. (EX1011+EX1031+EX1042)

The SCHOOL SET is like the set above but is fitted with stainless steel halyard and downhaul cleat and the sprit has no chafe protection tube.

EX1010	School mast.
EX1030	School boom.
EX1040	Sprit 25 mm.
EX1050	School set (EX1010 + EX1030 + EX1040)

The SLEEVE mast has no pin stop and has no stainless steel eyes for fixing the head of the sail and can be used with sleeve sail EX1061. The mast slides in the sleeve pocket of the sail and the sail has a loose foot. This eliminates the need of any sail ties on mast or boom.

A mast extender can be dropped in the top of the mast and moves the sail 10 cm up to create more headroom.

EX1012	Sleeve School mast.
EX10121	Mast extender (10 cm) for sleeve School mast.
EX1052	Sleeve School set. (EX1012+EX1030+EX1040)

RIGGING PACK made of high quality braided polyester lines. Include all halyard and control lines, bridle with ring, but no sailties.

EX1056	Upgraded rigging pack.
--------	------------------------

## HULL PROTECTORS

**BOW BUMPER.** Foam tubing covered by heavy duty polyester cloth.

This fender has a snug fit around the bow of the Optimist. Ideal for sailing schools. With grommet in the middle to pass the painter. For instructions: <http://www.optiparts.com/algemeen/manual.asp> or <http://www.optistuff.com/info/faqs-manuals.html#instructions>

EX1065	Bow bumper.
--------	-------------

**CORNER PROTECTORS.** Heavy duty rubber corner protectors with selfadhesive backing. These can be used on bow only or on all 4 corners. Special preshaped rubber profile. This is not a flat piece of thin rubber!

EX1066	Corner protectors =Set of 2 pieces=
--------	-------------------------------------

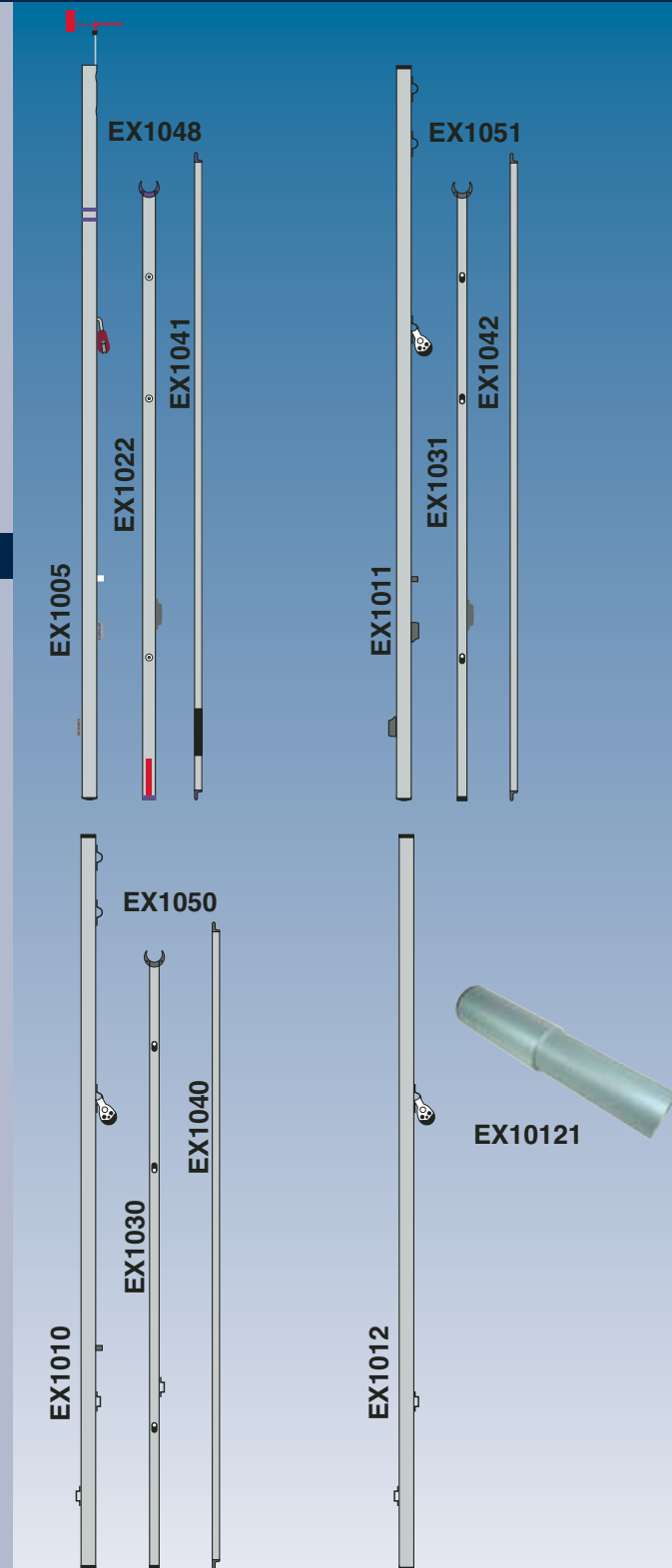

## SAILS

**OPTIMIST RACING SAILS.** Built for speed! Great care has been taken on each cut and stitch. Made of Polyant 140 B sailcloth. One of the best sailcloths available worldwide. Easy to trim 6 panel horizontal design.

With tapered sailbattens, telltales and window installed. Includes Vectran sail tie kit, sail bag and IODA button. Comes in 2 X cuts:

EX1057 Windesign Speed sail UNO (under 45 kg, 99 lbs)

EX1058 Windesign Speed sail DOS (over 45 kg, 99 lbs)

**OPTIMIST DURARACE SAILS.** A great sail for practice and sailors learning to race. Built for durability and speed! Made of 4.18 oz Challenge sailcloth. A bit more heavy but much more durable than sailcloth used in most racing sails. Same design and features as the racing sails above.

EX1057A Windesign Durarace LITE sail (under 45 kg, 99 lbs)

EX1058A Windesign Durarace POWER sail(over 45 kg, 99 lbs)

**OPTIMIST CLUB TRAINING SAIL.** Made of strong 4 oz. high quality 100% dacron sailcloth. 6 panels with nickel plated eyes. Heavily reinforced corners. Built to give many years of useful service in learn to sail schools. Comes complete with extra long sail bag for storage of sail and spars. With window, sailbattens, class logo and I.O.D.A. button. According to the last IODA class rules. Built to Last.

EX1059 Club optimist sail

**STANDARD SAIL.** as above, but without window, IODA button and logo.

EX1060 Standard sail without IODA button.

**SLEEVE SAIL.** ideal for sailing schools. A sleeve pocket for the mast at the luff with a cutout for the sprit halyard block. The mast slides in the sleeve pocket while the sail is loose footed on the boom. Made of strong 4 US oz. high quality 100% dacron sailcloth. This 5 panel sail has no sailbattens, 4 heavily reinforced corners and webbing loops to accommodate the boom. Should be used with sleeve mastset EX1052.

EX1061 Optiparts sleeve pocket sail. colored.

EX1061W Optiparts sleeve pocket sail. White (not shown)

**TRISAIL.** Half the size of a normal Optimist sail. Very easy to handle. Now even the smallest helmsman can continue sailing in heavy wind. Comes as a set with a sleeve mast, long mast extender and mini boom, With boom bumper head protector. The TRISAIL can also be used with a regular sleeve mast and boom with the addition of a 40 cm mast extender.

EX1061M Trisail only

EX1064 Trisail with mini boom, sleeve mast and mast extender

EX1446 Boom bumper head protector

EX10122 Mast extender 40 cm only (to be used with EX1012)

**OPTIPARTS CLUB SAILS ARE BUILT STRONG TO LAST LONG**

SPEED AND  
DURARACE

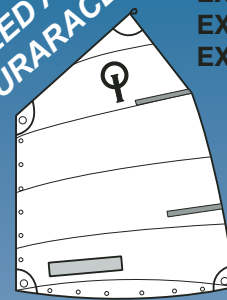

EX1057  
EX1058  
EX1057A  
EX1058A



CLUB

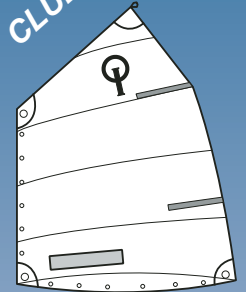

EX1059



EX1061

SCHOOL

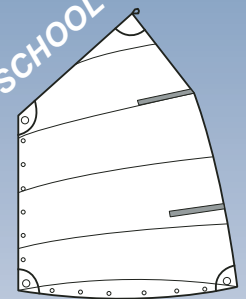

EX1060

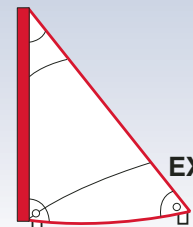

EX1061M

## SAIL ACCESSORIES

EX1416 Untapered sail batten, with plastic end caps.

EX1417 Tapered sail batten, with hole.

Class logo and sail numbers according to IODA and IYRU class rules.

EX1418 Optimist class logo. Color blue. =set of 2=

EX1419 Optimist computer sail number =set of 14=

Cut to make any number or letter.

EX142.... 0....9 Optimist sail number blue. =set of 10=

EX142.... Optimist sail letter blue. A,B,D,E,F,G,N,R,S OR U =set of 10=

16 Telltales (8 red and 8 green) In resealable display packing with instruction manual. With adhesive discs to fix the telltales to the sail.

EX1430 Telltales (min. order 10 sets)



EX1416



EX1417



EX1418



EX1419



EX142...



EX1430

## OPTIMIST SAIL AND RIG TRAVEL BAGS

Sailbag of red nylon cloth to protect your sail when rolled around the boom.

EX1062 Optiparts sailbag. 2 m long.

Optimist rig travel bag. Heavy duty bag from 600 polyester with two compartments for sail, boom, mast and sprit. With zip closure, name tag pocket and detachable and adjustable carrying strap. Can be bundled with 2 straps to create a compact package. Built to accept 100 mm (4") diameter thin-walled PVC irrigation pipe "To keep the sail from being crushed"

EX1063 Rig travel bag.



OPTIPARTS

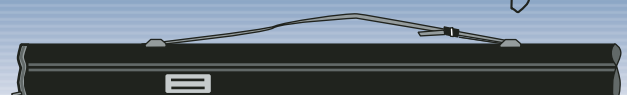

## COVERS

**Full batten top cover.** This cover has 2 sailbattens integrated in the top panel. The top panel will be tented when the webbing straps connected to both ends of each batten are tensioned. Made of Grey 600D pvc coated ripstop polyester. The padded panels on the front back and sides fold around the corners and protect your hull.

The new design allow you to remove the battens from the cover quickly. Each batten can be disconnected in the middle for easy storage.

EX1080 Padded full batten topcover Color: Light grey

**Breathable top cover.** Made of Moistureguard 2000, a heavy duty 900D polyester with a polyurethane membrane which has excellent breathability and is water-resistant.

The cover can be tented by storing the spars under the cover inside the boat. Wide skirts around the edge of the hull for good protection. Fast and easy to install with two straps with two adjustable quick-clip buckles.

EX1081 Breathable Moistureguard topcover Color: Light grey

**Low cost topcover.** Design like EX1081 but made of 600D pvc coated polyester. 100% water resistant but not breathable. Color: Light grey

EX1082 Optiparts topcover "economy", not shown

**Breathable undercover.** Made of Moistureguard 2000

Quick and easy to install with a 6 mm shockcord in the skirt and 2 straps with quick-clip buckles. With 3 wide strips of thick foam in the bottom to protect the hull (even from concrete) while being rigged. Color: Light grey.

EX1091 Optiparts undercover of "Moistureguard 2000"

**Fully padded undercover.** Provides the best possible protection during travel. 420 PU outside, new higher quality 190T interlining inside and closed cell foam in between. For all weather protection we suggest EX1091

EX1095 Optiparts fully padded undercover

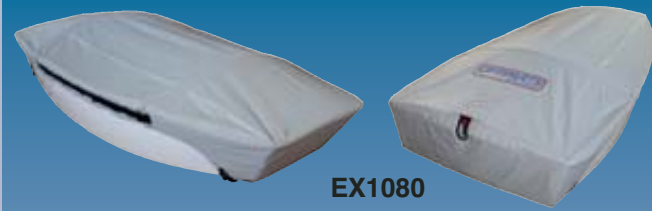

EX1080

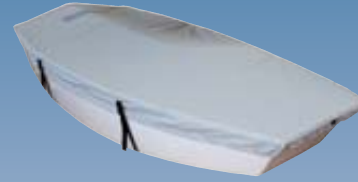
EX1082  
EX1081 (NOT SHOWN)

EX1091



EX1095

## TROLLEY / DOLLY

Aluminum trolley with small or large pneumatic wheels.

With stainless steel heel protector and BOW WOW! A unique system to lock the bow to the trolley with one quick and simple movement. Prevents the hull from sliding off on steep launch ramps. The trolley has been designed to be the most functional available. Spring locking (Quick release) of all parts allows the unit to be disassembled in a matter of seconds for storage and travel. Made of square Aluminum tube with rounded corners. The frame has welded joints and is anodized to prevent corrosion. The extended and pvc padded support allows the hull to be stored either right side up or up side down.

**NEW FOR 2010: Wide solid rubber wheels,** 28 cm diameter, 10 cm wide.

These wheels do not float and you will never have a flat tyre again ! EX1075 small wheel trollies will be supplied with these wheels from now on and can be used on all older Optiparts trollies.

**Stainless steel/alu push button wheel locks.** Replaces wheel securing clips. Can be mounted within the axle. So you will not loose your clips anymore. These can be used on older trollies but can not be used on older wheels with black wheel bushings.

Trolley padding kit. Consists of a foam tubing with 2 600D nylon protectors with Velcro fastener. It protects the hull and makes the surface slippery for easy launching. The padding runs over the full width of the trolley, so the middle is protected when turning the hull upside down.

EX1075 Optiparts trolley / Dolly solid rubber wheels, not shown

EX1076 Optiparts trolley / Dolly large wheels, shown

EX1077 BOW WOW replacement kit

EX1078 Spare pneumatic wheel, 26 cm

EX10784 Solid rubber wheel 28 cm

EX1079 Spare pneumatic wheel, 40.5 cm.

EX10790 Stainless steel spring clip for securing large wheels only!

EX10791 Galvanized spring clip for securing wheels

EX10792 Round button, spring locking system

EX10795 Push button wheel lock

EX10796 Trolley padding kit



EX1076

EX1078

NEW!

EX10784

EX10791

NEW!

EX10795

EX1079

EX10790

EX10792

EX1077

EX10796

## SCHOOL AND RACING FOILS

**ONE DESIGN RACING FOILS.** Built according to the new class rules. Class rules have standardized centerboard and rudder: size, shape, epoxy, foam and fiberglass. No longer do you have to pay high prices for World Class performance. Both rudder and daggerboard are made to the maximum allowed thickness to create a foil as stiff as possible under the given rules. The daggerboards are fitted with nicely finished teak wood battens. Our Racing foil sets which have a high level of finish are now also available with PRO finish. Both rudder and centerboard are wetsanded below the waterline. Creating less drag and a super smooth surface.

### GRP SCHOOL FOILS.

Grey or white GRP school foils. Less expensive than epoxy racing foils but Allows skipper to skull while preventing the boat from stalling. Intended for training and school use only.

### WOODEN SCHOOL FOILS.

Made of high grade marine plywood. Rudder of 12 mm and dagger of 15 mm marine grade plywood. Varnished 3 times. Least expensive foils available, for school and recreation only.

Rudderblades can be used with the tillers, extensions and rudderfittings on page 6 and are available with or without rudderfittings (mounted).

Add #

EX1100/ ...	Rudderblade (no fittings)
EX1105/ ...	Rudderblade with rudder fittings mounted
EX1110/ ...	Daggerboard
EX1114/ ...	Rudderblade and daggerboard (no fittings)
EX1115/ ...	Rudderblade and daggerboard with rudder fittings

ADD # 0	FOR GRP SCHOOL BLADES
ADD # 3	FOR WOODEN SCHOOL BLADES
ADD # 5	FOR EPOXY ONEDESIGN BLADES, STANDARD FINNISH
ADD # 6	FOR EPOXY ONEDESIGN RACING BLADES PRO FINNISH



EX11105



EX11055

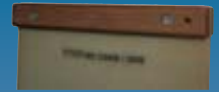

ONEDESIGN  
RACING  
ADD#5



ONEDESIGN  
RACING  
PRO FINNISH  
ADD#6

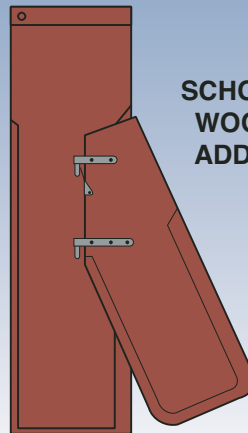

SCHOOL  
WOOD  
ADD#3

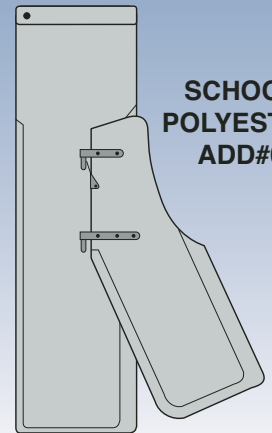

SCHOOL  
POLYESTER  
ADD#0

## DAGGERBOARD BUNGY WITH HANDLE

6 mm shockcord with red pvc handle to retain the daggerboard in its case. The legal handle to keep your daggerboard in place and your hiking strap up too. Comes in a complete set with 2 sizes of tubing, shockcord and 3 mm Vectran rope to keep the shock cord in place. Assembly instruction available on [www.optiparts.com](http://www.optiparts.com)  
EX1113 Daggerboard bungy



## RUDDER AND DAGGERBOARD BAG

The first cover you should consider buying. Not only does it protect your investment in foils but it proves a breathable compartment for all those items a young skipper will lose: Life jacket, gloves, sunscreen, glasses, etc. Constructed of 600 D Nylon, this blade bag is made to last. With 3 compartments for rudder, dagger and accessories. The rudder and daggerboard compartments are padded inside and out, protecting your blades from the outside world, and from each other. With shoulder strap and a space for sailnumber and name.

EX1119 Rudder/daggerboard bag Optimist



## DAGGERBOARD PROTECTION

A complete kit for protecting your valuable daggerboard: 4 rubber inserts, adhesive, sandpaper and 4 self-adhesive Teflon glide strips (300 x 18 x 1,0 mm each). These strips can be stuck to the top and the bottom of the case and minimize play and friction between the daggerboard and its case.

EX1117	Complete protecting kit as described above
EX11171	Roll of 8 m glide tape
EX1116	Rubber insert only. 1 pc
EX1116-10	Rubber insert only, 10 pcs



EX1117

EX11171

## TILLERS AND TILLER EXTENSIONS

EX1120	Aluminum tiller. 2 rectangular aluminum tubes mounted together. Plastic end caps Size of tubes 10 X 20 X 1.5 mm Suitable for all sizes of Optimist rudderblades. Silver anodized. Weight 265 grams
EX1122	Tiller as above, but black anodized
EX1125	Aluminum tiller (EX1122) complete with deluxe aluminum tiller extension EX1140 (releasable joint/swivel with rope core and new grip) All black anodized. Weight 390 grams.
EX1130	Aluminum tiller (EX1120) with standard aluminum tiller extension EX1142. All silver anodized.

Each tiller is supplied with nuts and bolts to mount it to a rudderblade.

EX1140	Deluxe tiller extension, Black anodized aluminum, With a releasable rubber joint/swivel and long black eva foam grip. The joint incorporates a fibre core molded up in the center. This fiber core will avoid complete failure should the rubber tear. Length 60 cm. Weight 128 grams
EX1141	Deluxe "Jamaica special" tiller extension. As above but with a multicoloured foam grip
EX1142	Standard aluminum tiller extension with rubber joint and golf grip. Silver anodized, Length 60 cm. Weight 150 grams.



## OPTIMIST RUDDER FITTINGS

The only perfect rudder fittings for the Optimist. Used on all top racing foils. Pin diameter 6 mm. (According to I.O.D.A. class rules) These stainless steel rudder fittings are available as a set or separate. Included in the set are pintles, gudgeons, backing plates and a rudder retaining clip. For blades up to 15 mm thick.

EX1150	Optiparts rudder fittings. Set complete (as shown) EX1160 + EX1170 + EX1180.
EX1155	12 Bolts and self-locking nuts, 6 for mounting the gudgeons and 6 for mounting the clip and the pintles.
EX1160	Optiparts rudder pintles 1 x long and 1 x short
EX1170	Optiparts transom gudgeons with backing plates
EX1180	Optiparts rudder retaining clip. Fits around the blade. Can be fastened with one bolt which will not split the blade.

**THESE WILL FIT NEW ONE DESIGN AND OLDER RUDDERS**

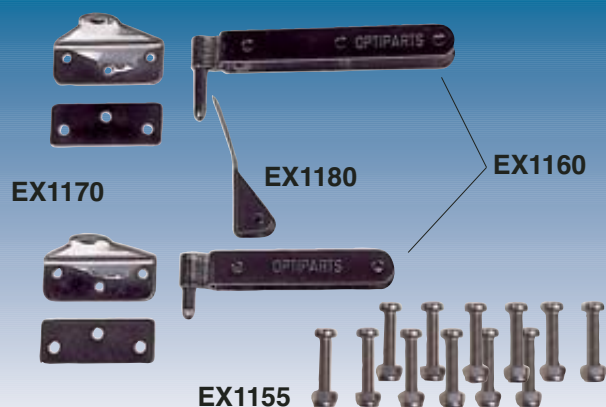

## OPTIMIST MASTSTEPS

The pin type maststep must be used together with the pin type heel plug. Friction between mast and maststep is reduced to a minimum. Most popular is our round type maststep. This maststep has an oval cup, which allows the mast to tilt forward when going downwind. Different mast rakes can easily be repeated using the scale on the base. Separately a mast step spring lock can be purchased. The stainless steel spring prevents the nut from turning accidentally. There is no need for additional locking nuts anymore.

EX1200	Adjustable maststep, racing type with pin, no lock system
EX1202	Adjustable maststep, round type, no lock system
EX1204	Round cup only
EX1205	Plate with pin only
EX1206	Base plate only
EX1207	New nut, with spring locking system
EX12071	Spring lock keeper



## MAST LOCK

Stainless steel lock to secure your mast from coming out of its step when the boat is capsized, causing costly foredeck damage. This lock has a rubber insert and should be clamped around the mast just under the deck. We suggest you use the collar in addition to the rope locking system to create double security.

The lock will be provided with a line to attach it to the maststep.

EX1203	Optiparts mast lock.
--------	----------------------



## DECK COLLARS

Standard nylon mast deckcollar. Hole size in deck: Ø 53 mm

EX1208 Standard nylon deck collar

2 Racing deck collars: Both have an oval and tapered inner diameter. The oval inner diameter allows the maximum fore/aft play and minimum side play. The tapered inner diameter allows the mast to be raked.

4 countersunk mounting holes. Hole size in deck: Ø 57 mm

EX1210 has a sperate sleeve which is fitted around the mast at deck level and protects the mast from wearing.

EX1209 Low friction, Delrin, deck collar, white

EX1210 Deck collar with mast sleeve, Grey

EX12101 Deck collar only

EX1211 Mast sleeve only (as supplied with Blackgold masts)

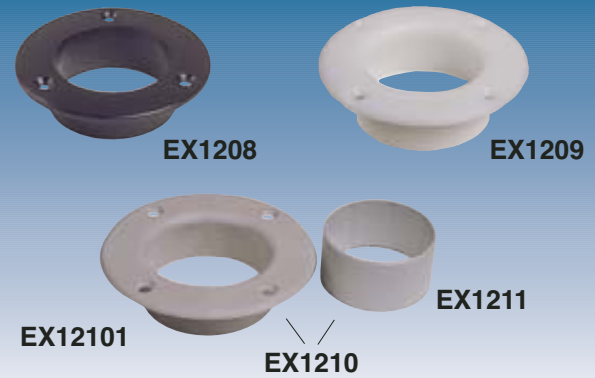

## OPTIMIST ROWING SEAT

Polyester rowing seat for IOD'95 and non IOD Optimists.

Unlike other rowing seats this seat consists of 2 separate sections which lock together in the centerboard case. Due to this unique construction the seat can be easily stored or transported. Comes without rowing locks.

Also available a set of 1.50 m long varnished wooden rowing oars or aluminum oars.

EX1230 Polyester rowing seat.

EX1232 Set of aluminum rowing oars

EX1233 Set of rowing locks



## HEAVY DUTY BUOYANCY BAGS

Heavy duty buoyancy bags. According to IOD'95 rules.

These bags are made of polyurethane coated nylon and are about half the weight and significantly stronger than bags made of PVC or PVC coated nylon. Some bags are available with a twist lock tube valve. This valve is attached to a piece of tubing. With this valve the bag can easily and quickly be inflated and deflated. 48L bags are slightly heavier than 43L bags but after a capsizing there is a lot less water in the boat.

EX1212 Optiparts buoyancy bag. Normal valve, Color yellow  
size inflated 29 cm x 92 cm, content : 48L  
size deflated 44 cm x 98 cm, radius 5 cm

EX1213 Optiparts buoyancy bag. Normal valve, Color white  
48 L, Size like EX1212.

EX1215 Optiparts buoyancy bag. Normal valve, Color grey  
size inflated 27 cm x 88 cm, content : 43L  
size deflated 41 cm x 100 cm, radius 24 cm

EX1216 Optiparts buoyancy bag. Twist lock tube valve. Color red  
43 L, Size like EX1215.

EX1217 Optiparts buoyancy bag. Twist lock tube valve. Color Blue  
48 L, Size like EX1212.

EX1218 Optiparts buoyancy bag. Twist lock tube valve. Color yellow  
48 L, Size like EX1212.

EX1219 Optiparts buoyancy bag. Twist lock tube valve. Color red  
48 L, Size like EX1212.



## PVC BUOYANCY BAG

Made of, high quality flexible pvc foil. With non return valve.

Suitable for all non IOD'95 Optimists and other classes.

Can be used inside GRP tanks or with straps.

Size inflated 24 cm x 92 cm, content : 43 L

EX1220 Optiparts pvc buoyancy bag. Color white

## SPRIT ENDS AND MAST PLUGS

Optiparts owns several molds for producing custom end fittings. All boom end fittings are made of high quality glass fibre filled nylon. Unlike inboard boom-end fittings from other manufacturers ours have a firm grip around the mast. This ensures that mast and boom turn together. When retrofitting an old mast with a high heel plug first make sure the total mast length will not exceed 2350 mm. Sizes are outside tube diameters.

EX1275	Inboard end for 32 mm standard boom (for EX1030)
EX1276	Outboard end for 32 mm std. boom (for EX1030)
EX1280	Inboard end for 40 mm racing boom (for EX940)
EX1282	Outboard end for 40 mm racing boom (for EX940)
EX1284	Inboard end for 45 mm racing boom (for EX945) not shown
EX1285	Outboard end for 45 mm racing boom (for EX945) not shown
EX1281	Inboard end for 55 mm racing boom (for EX955)
EX1283	Outboard end for 55 mm racing boom (for EX955)
EX1255	Heel plug, Low friction Delrin, for racing mast
EX1256	High Heel plug, Low friction Delrin, for racing mast
EX1257	Heel plug, heavy duty, for silver and school mast
EX1260	Top cap, to seal the top of a silver and school mast. =not shown=
EX1270	Sprit ends for standard 25 mm sprit. =per set=
EX1271	Sprit ends for racing 27 mm Blackgold sprit. =per set=
EX1272	Sprit ends for racing 29 mm Blackmax sprit. =per set=
EX1290	Mast flotation plugs, made of natural cork. =set of 3=



## SPAR ACCESSORIES

EX1333B	Measurement band sticker blue
EX1333G	Measurement band sticker gold
EX13371	Button used for the downhaul on the School booms
EX13372	Pin stop as used on the Silver and School mast
EX13373	Button as used on the Gold, Silver and School booms
EX1339	Lacing eye "bridge" as used on Blackgold booms.
EX1337	Pin stop as used on the Blackgold and Gold mast. Black anodized Aluminum with 3 mm hole for mounting. Provides more effective downhaul function.
EX1336	Lacing lines for mast and boom, all in Vectran. Five 3 mm tack lines and sixteen 1.2 mm lacings. All lacing lines are now double length.
EX1338	Optiparts top pins, which do not cut the lines, as supplied with racing masts. =set of 2=
EX1354	Nylon sprit adjuster handle with hole for 4 mm rope. For easier handling of the halyard.
EX1355	Sprit protection for both 27 and 25 mm sprits. Length: 15 cm. Heat shrinkable tubing for protection between sprit and mast. Can be applied with a hair dryer or paint stripper.
EX1358R	Trim strip. Red Length 16 cm. =pack of 20 pcs=
EX1358G	Trim strip. Gold Length 16 cm. =pack of 20 pcs=
EX13591	Rigging pack as with BLACKGOLD set. Contains: halyard EX1352 + Vectran line, wind indicator EX1242, top pins EX1338, Vectran lacing lines and a halyard handle EX1354.
EX13593	Rigging pack as with SILVER set. Contains: halyard EX1340, wind indicator EX1242 and top pins.
EX1364	Vang for 32 and 40 mm booms
EX1365	Vang for 55 mm booms



## WIND INDICATORS

We supply a standard wind indicator, with a red PVC flag on a wire frame, which is currently used on many optimists and other dinghies. The most popular is our, low friction, racing wind indicator. Both have a 5 mm shaft, which fits all common top pins (pennant holders).

EX1240	Standard wind indicator
EX1240-10	Standard wind indicator. =10 pack=
EX1242	Low friction racing wind indicator
EX1242-10	Low friction racing wind indicator. =10 pack=
EX1245	Wind indicator, clip for school mast

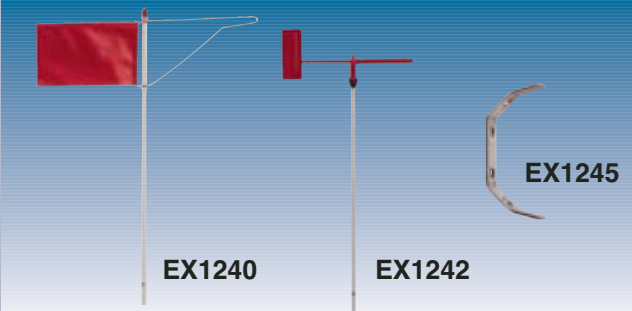

## BOOM ACCESSORIES

EX1360	Boom bridle, 3 mm Vectran with stainless steel ring for mainsheet.
EX1362	Stainless steel rings 15 mm
EX1362-10	Stainless steel rings 15 mm. (pack of 10)

Carbine hooks are not safe and no longer allowed to attach the mainsheet block to the bridle. We supply 2 solutions :

EX1371	Small stainless steel safety snap shackle for the mainsheet. Length 43 mm, weights just 16 grams.
EX1372	Stainless steel 316 trigger snap safety snap shackle. Can be opened with one hand. Length 49 mm, weights 20 gr.
EX1373	Protest flag. Little pouch with a cord at the top to tie it to the boom and a Velcro closure at the bottom. Pull the bottom cord and the protest flag comes out.

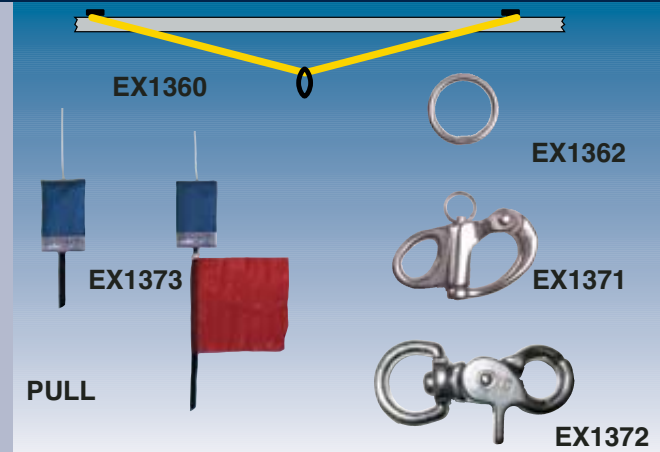

## MAINSHEET BLOCKS

Ronstan 55 mm Automatic and Manual ratchet in one block with up to 20:1 holding power. This block can be easily fitted and securely retained with a Dyneema® Link. Weights only 78 grams.

EX1294	Ronstan ratchet block
Harken 57 mm Carbo Ratchet. Machined aluminum sheave with 8 facets to hold the line securely. Weighs only 85 grams. Supplied with 2 way link.	
EX1296	Harken 2135 ratchet block, with 2-way link.
EX12961	Harken 2-way link, can be used on EX1297 too.
Clear ball bearing ratchet block. 57 mm. Most economic ratchet available.	
EX1297	Clear ratchet block.
Elvström ratchet block with plastic with stainless steel cheeks. Plain bearing but indestructible.	
EX1298	Elvström ratchet block.

Harken Carbo blocks. Compact, ultra light weight and extremely strong. For mainsheets and control lines and can be used as becket blocks too.

EX1306	Harken 29 mm single carbo block
EX1308	Harken 40 mm single carbo block
EX1313	Set of Harken blocks (EX1296 + 2 x EX1308)
EX1314	Harken 40 mm block spliced with Vectran line to a safety snap shackle. A must have for the top competitor.
EX1317	Harken 40 mm block with safety snap shackle attached

Ball bearing blocks with 38 mm sheaves. With stainless steel load straps. Simple ball bearing block for mainsheets up to 10 mm.

EX1315	Ball bearing block
EX1316	Ball bearing block with becket

Standard blocks for mainsheets with stainless steel cheeks and nylon sheave. Sheave diameter 34 mm. For ropes up to 10 mm.

EX1318	Standard block
EX1320	Standard block with becket

Plain bearing Windesign injection molded blocks.

Nylon cheeks and acetal sheaves. Lightweight, very strong and affordable. These mainsheet blocks are designed for Optimists and other small dinghies and can be attached with ropes, webbing and shackles. The cheeks can be opened and then the blocks can be attached direct on existing deck eyes. For ropes up to 8 mm.

EX1325	Becket block with 34 mm sheave
EX1326	Fiddle block with 34 and 20 mm sheave
EX1327	Fiddle block with EX1372 swivel trigger snap
EX1328	Single block with 34 mm sheave

EX1375 Mainsheet system for SCHOOL Optimist  
6 m, 8 mm mainsheet with 3 shackles 1 spring and 3, blocks (2 x EX1318 and 1 x EX1320).

EX1376 Optimist mainsheet system RACING optimist  
6m, 8mm, mainsheet, 2 shackles, 1 spring, 2 ball bearing blocks (EX1315 + EX1316), a ratchet block (EX1297) and a shackle (EX1372).



## BASEPLATES, SHACKLES AND SPRING

EX1301	4 mm plate shackle to mount standard mainsheet blocks EX1318 and EX1320.
EX1302	5 mm plate shackle to mount Elvström ratchet block and ball-bearing mainsheet blocks EX1315 and EX1316.
EX1304	Stainless steel spring to mount under ratchet blocks.
EX1410	Swivel base plate, four 5 mm holes.
EX1412	Base plate, fixed, four 5 mm holes. For mainsheet and hiking straps.
EX1414	Small eye, 4 mm holes, 1 mm thick, 10 x 9 mm opening , distance between holes 24 mm.
EX1415	Large eye , 5 mm holes, 2 mm thick ,15 x 13 mm opening , distance between holes 36 mm.

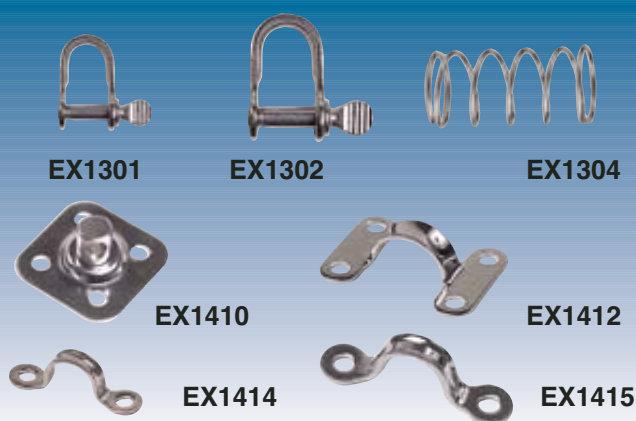

## BLOCKS AND HALYARDS

EX1330	Halyard block as used on SCHOOL mast, stainless steel cheeks, nylon 22 mm sheave, plain bearing.
EX1331	Halyard block as above, with becket
EX1332	19 mm plain bearing block as used on SILVER mast halyards.
EX1334	16 mm HARKEN micro block.
EX1340	Plain bearing Optiparts hook-in block as used on Silver masts.
EX1342	Plain bearing halyard as used on Silver masts.
EX1345	29 mm HARKEN Tie-Lite block as used on Halyards of Blackgold masts.
EX1351H	HARKEN Ball bearing hook-in block as used on Blackgold racing masts. Due to the curved saddle the block rests against the mast in a fixed position which prevents mast wear and creates a halyard system with less friction. Worldwide exclusively distributed by Optiparts
EX1352	Halyard system as used on Blackgold masts. 3 mm ultra low stretch Vectran with spliced loops. Complete with the HARKEN hook-in block and 29 mm tie-lite block. The combination of low weight, low friction Harken blocks and spliced Vectran rope creates the most advanced halyard system available on the market. Weighs only 28 grams.
EX1353	Replacement halyard line. (not shown) 3 mm Vectran halyard with 2 spliced loops. This line can be weaved through the Harken blocks.



## VECTRAN MINIREELS

Now available 3 mm Vectran without cover with uv protective coating. Constructed in such a way to facilitate easy splicing.

EX1366	Mini reel of 3 mm pure Vectran line length 16 m (52ft)
EX13661	Stainless steel splicing needle (fid)
Vectran minireels, black with gold fleck polyester cover.	
EX1367	Mini reel of 1.2 mm Vectran line Black with gold fleck. For Lacing lines. length 15 m (49ft)
EX1368	Mini reel of 3 mm Vectran line Black with gold fleck. For corner and bridle ties, length 16 m (52ft)
EX1369	Mini reel of 4 mm Vectran line Black with gold fleck. For sprit lift cleat line, length 12 m (39ft)

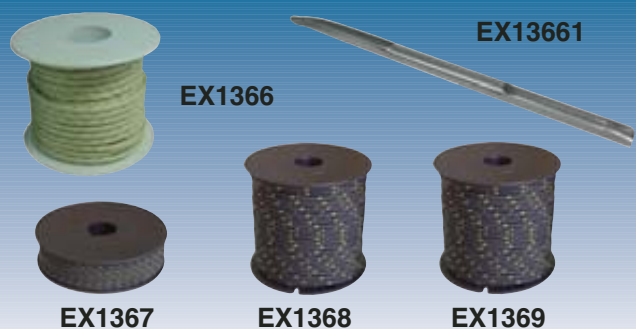

## OPTIMIST MAINSHEETS AND PAINTER

EX1374	Optimist painter 8.1m, 6mm, 16 plait polypropylene.
EX1377	Optimist mainsheet 6m, 8mm, 16 plait polypropylene. Rooster rope optimist mainsheet. Due to the unique design the cover takes the load instead of the inner core. This prevents the rope from tangling.
EX1378	Optimist mainsheet 6m, 7 mm, Rooster rope. The ultimate Optimist mainsheet is tapered and made of abrasion resistant PES material. Tapered from 9 to 6.5 mm. Thick and soft where it touches your hand. Thin and smooth elsewhere for free running control. Tapered on both ends. Long enough to create a 4:1 mainsheet with 2 boom blocks.
EX1379	Double tapered Optimist mainsheet

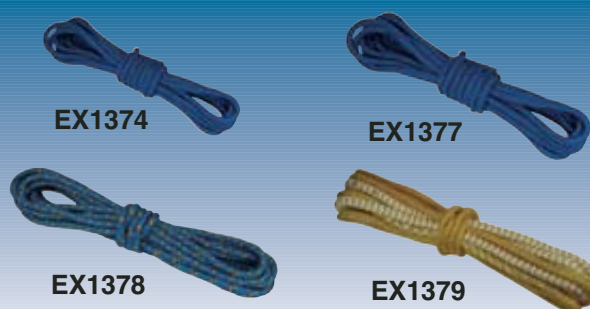

**OPTI HIKING BENCH**

Opti Hiking Bench. Fully detachable hiking bench with adjustable hiking strap.  
 This is the ultimate for hiking fitness while you are watching TV, reading a book or playing a video game. This light weight, super strong hiking bench is made from the same materials as the well known Optiparts dolly and is just as easy to assemble.  
 Perfect for that extra training session and very portable. Only 3.7kg (8 lbs).

EX1500 Opti Hiking bench



EX1500

**CLEATS**

- EX1381 Aluminum cleat (CL211 Mk2) for downhaul or halyard on GOLD and SILVER mast. Silver coated.
- EX1380 Hard anodized Aluminum clamcleat for downhaul on the BLACKGOLD mast.
- EX1399 Hard anodized Aluminum clamcleat with becket for halyard on BLACKGOLD MAST.
- EX1402 Stainless steel V cleat for SCHOOL masts and booms
- EX1405B Blue nylon V cleat for SILVER and SCHOOL booms
- EX1405G GREY nylon V cleat for BLACKGOLD booms



EX1381

EX1380

EX1399

EX1402

EX1405B

EX1405G

**DVD'S AND CD ROM**

**OPTISAILORS DVD "Advanced boat speed"**. Top boatspeed is demonstrated by different size sailors in all conditions and directions. Having the boatspeed of the top sailors is the only way to race competitively. With 3d animations and an optisailor poster included. This DVD has subtitles in French, Spanish, German and Italian language. **"Advanced Boat Handling"** was the first Optisailors DVD and has been shot with some of the best sailors from different countries in the world. It was shot with different cameras and angles, including an On board camera. With a playing time of 55 minutes. The DVD includes 6 sections with on land and on water explanations, tacks, double tacks, jibes, mark roundings and 720's. English spoken and it also Contains 5 Clips with very cool shots coordinated with music (12 minutes)

The instructing on both DVD's has been done by Alejandro Sole, and Gonzalo Pollitzer. Both International Optimist coaches and ex Optimist champions (European-, Southamerican- and Worldchampions).

- EX1432 Optisailors, Advanced boat speed DVD
- EX1433 Optisailors, Advanced boat handling DVD



EX1432



EX1433

**ULTIMATE OPTI RACING** The Ultimate Opti Racing DVD is the premier instructional DVD for the optimist sailor who wants to learn how to be competitive; from green fleeters and beyond. This DVD covers boat and sail set-up, boat speed, boat handling, racing tips and course management in all weather conditions. It is fast paced and covers a lot of information on how to sail in light, medium and heavy wind.

This 35 minute instructional DVD is the complete learning tool for Opti sailors who want to find the competitive edge.

EX1434 Ultimate Opti racing



EX1434

**NEW RACING RULES DVD** With rule changes for the new 2009-2011 ISAF Racing rules of sailing. This DVD uses an interactive menu and covers the rules all around the course. It shows the most frequent situations that occur and explains which are the rights and duties in each case. It combines different footage of top Optimist and Laser® sailors with 2D animations. This, plus the narration in English and Spanish, created a unique DVD!

The DVD has 55 minutes of action with amazing footage of top sailors in Caribbean waters and excellent music background.

EX3032 Racing rules DVD



EX3032



**OPTICOACH** will help you to improve your racing skills. There are 3 comprehensive chapters covering Boat Preparation, Technique and Tactics. You can choose any point on the racecourse in any conditions and watch video on how some of the best Optimist Sailors in the world perform.

EX1435 Opticoach CD ROM.



EX1435



**PRADDEL PADDLE, WHISTLE, BAILERS**

Single handed paddle. Can be used with one arm only while steering with the other arm. Weighs only 215 grams.

**High visibility orange for safety signaling and easier recovery.**

Please contact us for a quotation for quantities over 50 pcs.

EX1440 Praddel paddle.

EX1441 Plastic whistle with lanyard.

Large hand bailer. Strong construction and large handle

Contents: 3.5 litre. Fits perfectly to the corners of the IOD'95 hull.

Weights only 210 grams. Available in Red and Green for port and starboard.

EX1442R Handbailer 3.5 litre, color Red.

EX1442G Handbailer 3.5 litre, color Green.

EX1443 Plastic hook for securing praddel, bailer or centerboard

Small handbailer, for sailing schools and other dinghies.

EX1444 Handbailer small, color orange.

Sponge stick. Grows from a compressed stick to a full sized sponge.

High quality, biodegradable & environmentally friendly cellulose sponge.

EX1445 Optiparts sponge stick



**HIKING STRAPS, WEBBING AND MOUNTING PLATES**

Kiwi style padded hiking straps, for comfortable hiking. Strong Nylon webbing partly covered with wear resistant cloth filled with foam plate material, which does not absorb water. Strong stitched through construction.

On the aft end a pressed ring and sewn flat to prevent twisting. Loops for shockcord. The front ends are open for mounting with plate or rope.

EX1450 Padded hiking straps, per pair.

EX1451 Hiking straps (not padded), per pair =not shown=

Stainless steel and Nylon plates with two holes for mounting hiking straps and buoyancy bags. Due to a recent rule change Nylon plates are now allowed in the optimist. Thickness: stainless 2 mm, nylon 4.5 mm

EX1453-10 Stainless mounting plate (pack of 10)

EX14531-10 Nylon mounting plate, black (pack of 10)

EX14532-10 Nylon mounting plate, red (pack of 10)

EX14533-10 Nylon mounting plate, blue (pack of 10)

Polypropylene buoyancy bag webbing. 1.2 mm thick, 50 mm wide.

EX1460 Webbing roll of 50 m, color: RED

EX1462 Webbing roll of 50 m, color: BLUE

EX1464 Webbing roll of 50 m, color: BLACK

EX1466 Webbing roll of 50 m, color: WHITE



**PROMOTION / GIFT ITEMS**

Optimist model, scale 1:10. Made with great detail.

Polyester hull with aluminum spars, metal fittings, rudder and daggerboard, airbags and preshaped sail. Displayed in acrylic box.

EX1470 Optimist model

Simple inexpensive Optimist model, scale ± 1:15.

Complete with spars, sail, foils and 3 airbags.

For prizes or as a small gift.

Hull: 16 cm long, with wooden stand.

EX1471 Simple Optimist model

Optimist mini sail, scale 1:6 , 47 cm high. , Made of real Dacron, with window, sailbattens and class logo. Reinforced corners with eyelets.

Kids love these. They let their friends sign them during regatta's.

EX1472 Optimist mini sail

Flexible rubber key ring with Opti class logo. 8 cm high

EX1475 Opti key ring, Blue

EX1476 Opti key ring, Green

EX1477 Opti key ring, Red



**BREATHABLE SPRAYTOP**

High quality Windesign breathable spray tops.  
Breathable but waterproof with waterproof taped seams.  
Designed for freedom of movement.  
Adjustable latex neck and wrist seals and adjustable neoprene waist belt.  
Pocket with waterproof ykk zipper and drain.  
w/p (waterproof) 10.000 mm MVP (Breathability) 4.000 g/m2/24hr  
Color adult sizes: Navy with light grey details  
Color Junior sizes: Red with light grey details  
Available in JS, JM, JL, S, M, L, XL,

EX2440J.... Breathable Spraytop Junior  
EX2440.... Breathable Spraytop Adult

SIZE	JS	JM	JL	S	M	L	XL
CHEST CM	71-77	78-85	86-91	89-95	96-103	104-111	112-117
CHEST INCH	28-30	31-33	34-36	35-37	38-40	41-43	44-46
YEARS	6-8	9-11	12-13				



JUNIOR

ADULT

**NEOPRENE SAILING BOOTS**

Sailing boots made of 5 mm neoprene with molded sole.  
High quality YKK side zipper for easy entry, Rubber reinforced neoprene upper for hiking, Flat locked seams for improved comfort, Zip protection flap, Velcro zip lock.  
Lightweight, only 780 grams a pair.

EX2450.... Neoprene sailing boots

WINDESIGN	J1	J2	J3	J4	J5	XS	S	M	L	XL	2XL	3XL
UK	1	2	3	4	5	6	7	8	9	10	11	12
EUROPE	32/33	34	35	36	37/38	39	40/41	42	43/44	45	46	47/48
USA MENS	1.5	2.5	3.5	4.5	5.5	6.5	7.5	8.5	9.5	10.5	11.5	12.5



**KIDS HIKING PANTS**

Made of very strong and durable 600D polyester. Each leg part has stiff polyester battens covered in closed cell foam to spread the pressure of the edge of the boat. The leg straps, 2 on each leg, have Velcro closures and elastic sections to increase general comfort. Waist can be rolled over to adjust where the battens hits leg.  
In special small sizes for kids.

SIZE	JS	JM	JL
WAIST CM	53-67	60-76	69-86
WAIST INCH	20-26	24-30	27-34
YEARS	9-11	11-13	13-15

EX2500.... Hiking pants. ( JS, JM or JL)



AVAILABLE  
IN SMALL  
JUNIOR  
SIZES

**NEOPRENE HIKING PANTS**

3/4 length 3 mm WS-2 neoprene hiking pants with flat-stitched seams.  
With adjustable, preshaped batten pads and adjustable shoulder braces. These batten pads are fixed with Velcro inside the leg section and can be moved up or down to the most comfortable position.  
Small diamond reinforced seat section for improved abrasion resistance. The knee section is padded and reinforced with a stretchy material to allow for a good fit on all leg sizes.  
Size chart available on : [www.windesign.eu](http://www.windesign.eu)

AVAILABLE  
IN SMALL  
JUNIOR SIZES

EX2510.... Neoprene hiking pants ( JS, JM, JL, S, M, L, XL)



**BUOYANCY AID (50N)**

Designed for the dinghy sailor.  
With large body cut for freedom of movement.  
YKK side zip with Velcro security. Soft pvc foam, padded and elasticated shoulders for flexibility and comfort.  
Additional features are a large front pocket with velcro closure and a mesh pouch.  
CE approved (50N)  
Suitable for competent swimmers and mainly used for surface watersports like dinghy sailing.

XS SIZE FOR KIDS FROM ± 6 YEARS

L	80-120CM	70+KG	50N	
M	70-100CM	70+KG	50N	
S	65-90CM	40-70KG	50N	
XS	55-70CM	30-40KG	35N	

EX2520..... Windesign buoyancy aid (50N) (XS, S, M, L)



EX2520.....

## GLOVES

New design short finger gloves. Black and grey Amara leather. Synthetic leather palm with cut out and anti-slip protections.

Black spandex elastic back and adjustable neoprene wrist strap.

Kevlar reinforced finger sections and double stitching.

EX2550.... Short finger sailing gloves (JS ,JM ,XS,S,M,L,XL)

Full finger neoprene gloves. Amara leather padded palm and navy neoprene back with blue neoprene at cuff. Amara leather between the fingers and an adjustable wrist strap. These gloves are designed to keep your hands warm during cold days in winter and spring.

EX2555.... Full finger neoprene sailing gloves (JS ,JM ,XS,S,M,L,XL)

REUSABLE DISPLAY  
PACKING  
AND  
AVAILABLE IN  
JUNIOR SIZES



EX2550.....



EX2555 .....

## SPREADERBAR TRAPEZE HARNESS

Made of long lasting 600D polyester with several features for the one design dinghy competitor. A wide spreader bar with hook, adjustable back support and stainless steel buckles. Padded and pre-shaped shoulder straps with loops to attach to the sailing jacket.

Reinforced seat section and neoprene padded adjustable leg straps.

EX2560.... Trapeze harness (S/M , L or XL)



## BAGS AND ACCESSORIES

Gear bag, made of 600D polyester with 5 compartments. Specially designed for the dinghy sailor. 2 large wet and dry compartments with heavy duty zippers. The wet compartment folds away when not in use. 2 zipped end pockets, one with netting for wet items the other one has a separate pocket from PX10 sailcloth with a Velcro closure. Comes with nametag pocket and detachable strap. Size 70 x 35 x 30 cm

EX2570 Gear bag.

Briefcase of PX10 sailcloth to hold a laptop or papers.

5 zipped compartments, pockets for wallet, phone and pencils

EX2572 PX Briefcase.

Tool/toilet bag of PX10 sailcloth, size 10 x 10 x 30 cm

EX2573 PX10 Tool/toilet bag.

Duffel bag of PX10 sailcloth and 600D polyester. Handy bag with separate pocket with zipper on each side. With name tag pocket.

Size 50 x26 x26 cm

EX2574 PX10 Duffel bag.

NEW Roller gear bag, made of long lasting 600D polyester.

1 giant main compartment and 5 small compartments on the outside.

The main compartment zips open like a suitcase so you can get to all your stuff with ease. The small compartments are made of PX10 sailcloth giving this bag an incredible look. Comes with a nametag pocket and detachable shoulder strap. Size 80 x 48 x 38 cm

EX2575 Roller gear bag.

All-purpose roll top waterproof drybag made of strong vinyl coated fabric. Designed for punishment this extra large roll top drybag is very durable.

The rolled top with buckle acts as a handle.

An additional handle is mounted on the side.

EX2576 Dry bag 45 L

A dry document folder, ideal for coaches. This folder has several pockets, a water resistant zip and a strap with buckle to secure it while on the water.

EX2577 Dry document folder

Waterproof phone bag. Made of touch flexible vinyl. Also ideal for camera, cash, credit cards and valuables. Inside size 9 x 17 cm.

EX2578 Waterproof bag for phone, wallet or camera

EX2580 Optiparts cap. 6 panel khaki cap with 2 color Optiparts logo embroidery.

EX2585 Optiparts belt. Universal size with metal buckle

EX2588 Floatable key chain



**SUNGLASSES WITH POLARIZED LENSES**

POLARIZED LENSES are the top pick for sailors because they eliminate glare created by light off shiny surfaces like water. Each pair of glasses is packed in a clamshell case and comes with a lens cleaning cloth. Available in Junior and Adult models. The Junior glasses are printed with a cool Opti logo. TAC polarized lenses with 100% UVA and UVB protection.

EX2590	Junior sunglasses
EX2595	Adult sunglasses



**ROOF RACK COVER AND LOAD STRAPS**

Foam tubing covered with heavy duty nylon cloth with Velcro fastener. Protects your boat from being damaged when transported on a roof rack.

EX1446	Padded roof rack cover.
--------	-------------------------

Set of 2 high quality extra long load straps with protection behind the buckle. Makes loading and transporting boats a quick and safe procedure. Cam-action buckle and high quality polypropylene webbing. 6 m long 25 mm wide.

EX1447	Load straps =set of 2=
--------	------------------------



**DIGITAL REGATTA TIMER**

This unique water resistant starting timer has huge 30 mm digits and a synchronize function in case you missed a signal. Beeps during the last minute every 10 seconds and during the last 10 seconds every second. Sound is on/off switchable.

- Water Resistant (IP67)
- Rigid casing with 3m velcro fixing
- Dimension : 90 x 76 x 23 mm
- Quick set/reset
- Replaceable AAA battery
- Auto shut-off

Universal timer bracket. You can now fix the timer anywhere you want. Screw the bracket to a flat surface or fix it on a mast or boom with the provided back to back velcro strap. The bracket can also be fixed to an airbag strap of an Optimist dinghy.

EX3010	Digital regatta timer
EX3012	Timer mounting bracket



**WINDESIGN WATCHES**

The WinDesign watches we introduced in the last few years are extremely popular and used by many Olympic sailors. EX3018 with start timer and sync. This most popular model has very large digits, is easy to set and reset and has a synchronize function in case you missed a signal. It beeps every minute, during the last minute every 10 seconds and during the last 10 seconds every second. Sound is on/off switchable and the timer can be set to repeat or count up after the starting signal. EX3015 has no start timer and no sync.

Both watches are 100m water resistant with the following features:

- ABS case with Stainless Steel cover)
- PU Strap
- Day, Date, Time (12 or 24-hour format)
- Chronograph
- Stainless Steel caseback
- Dual Time function
- Daily Alarms
- EL Backlight

EX3015	Windesign Regatta watch, with normal countdown, Blue
EX3018	Windesign Racing watch, with starting timer, Grey



**STORAGE**

Waterproof lunch container, stores your lunch or valuables dry. Keep the container in your own boat or in the coach boat. With a hole in the lid to attach a line. 2 sizes: 3 litre, 17 cm high and 6 litre 26 cm high.

EX3048	Lunch container 3 Liter
EX3049	Lunch container 6 Liter

Storage bag. Can be mounted under existing hatches with the supplied fixing screw. Allows you to store your valuables and drinks while afloat.

EX3060	Removable storage bag
--------	-----------------------



**TILLER EXTENSIONS**

**STANDARD EXTENSIONS.** Of silver anodized 16 mm aluminum tube. Fitted with a fixed rubber swivel joint and a golf grip handle.

**DELUXE EXTENSIONS.** of black anodized 16 mm aluminum tube. Fitted with a releasable rubber joint/swivel and an eva foam grip.

The releasable rubber joint/swivel has a rope core and is mounted with an Aluminum pin only. The pin is kept in place by a piece of heat-shrinkable tubing for easy replacement.

**CARBON EXTENSIONS.** All the features of the deluxe extensions but made of 16mm unidirectional carbon covered with a braided carbon outer with a high gloss finish.

size	Standard	Deluxe	Carbon
60 cm	652406	652306	652206
70 cm	652407	652307	652207
80 cm	652408	652308	652208
90 cm	652409	652309	652209
100 cm	652410	652310	652210
110 cm	652411	652311	652211
120 cm	652412	652312	652212

**20 MM CARBON EXTENSIONS.** Ultra stiff and long length. Super light weight yet stiff due to the increased tube diameter. Tube construction and swivel joint like above but with a simple end cap.

652112	Carbon Deluxe 20 extension 120 cm.	160 grams
652119	Carbon Deluxe 20 extension 190 cm.	210 grams
652125	Carbon Deluxe 20 extension 250 cm.	260 grams

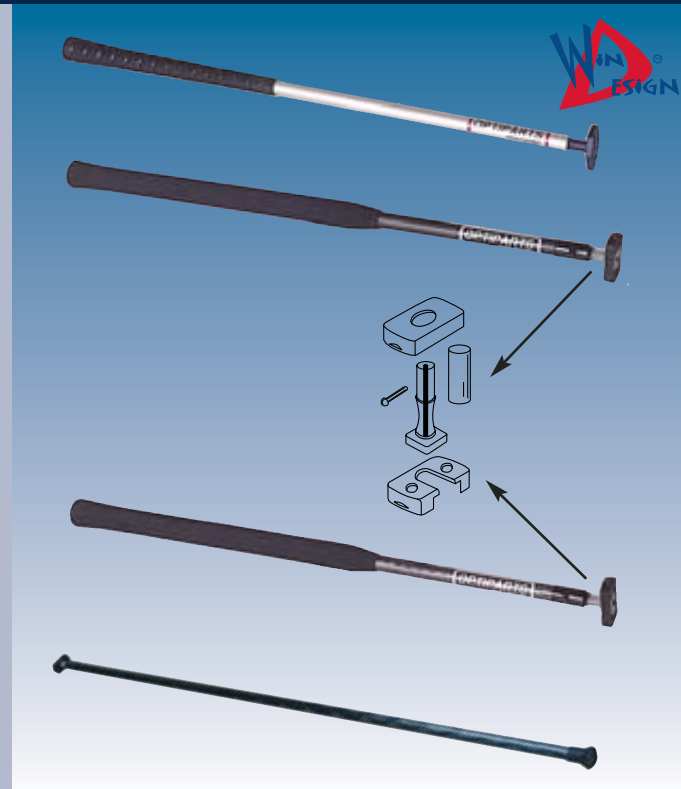

**JOINTS / SWIVELS, GRIPS, SADDLES AND CLIPS**

Releasable rubber joint/swivel is mounted with an Aluminum pin only. The pin is kept in place by a piece of heat shrinkable tubing. To remove a joint : simply cut off the tubing and push the pin out.

The joint incorporates a fibre core molded up in the centre. The fibre core will avoid complete failure should the rubber tear which allows you to finish the race. Also available is the less expensive full rubber joint and the joint with rope core without releasable base.

The distance between the mounting hole centers of all joints is 32 mm.

652944	Joint without rope core.
652948	Joint with rope core, fixed base.
652950	Joint with rope core, releasable base with pin and tubing.

Both, the 16 mm carbon and the Aluminum Deluxe extensions, now come with a 36 cm long lightweight, thick eva foam grip.

This grip weights only 26 grams and is available in black and multi colour A 26 cm long golf club grip is used on the standard tiller extension.

652960	Golf club grip black.
652961	New lightweight, eva foam grip, BLACK.
652963	New lightweight, eva foam grip, Multicolored.
652965	Clip for both extensions.
652998	Saddle for mounting all extensions on ø25 to ø32 mm tube.



**MASTFLOAT**

This mast float significantly reduces the risk of inversion. A very neat design of 2 inflatable tubes connected with a piece of sailcloth. The sailcloth can be folded around the rope inside the sailtrack. The mastfloat is hoisted with the sail.

Each tube has a length of 80 cm and can contain 4 liter air, so total buoyancy is 8 liter.

Please note this product is meant for small dinghies only and does not guarantee 100% protection against inversion. Using it is for own responsibility. The product is inflated by mouth.

EX2600	Mastfloat
--------	-----------



**COVER FOR 420'S**

420 top cover, made of heavy duty, long lasting 1680D polyester/pvc. 100% water resistant and rot free. 3 straps with quick clip adjustable buckles go underneath the hull and hold the cover tight. Color: Light grey.

EX2046 420 top cover

Bottom cover of strong, yet flexible, 600D polyester PU coated. Color: grey.

EX2048 420 bottom cover

Fully padded 420 mast cover. Tapered towards the top with reinforced openings for hounds and spreaders. Several straps for tying excess material. Velcro closure runs from hounds to heel for quick and easy packing. With red safety flag. 600D polyester pvc with 5 mm closed cell foam and tarpaulin lining.

EX3025 Padded 420 mast cover

Fully padded 420 boom cover. Same construction as the mast cover above but with 120 cm long zip for easy access.

EX3026 Padded 420 boom cover

Fully padded 420 rudder and daggerboard cover. Protect your expensive foils when on shore and during transport.

EX3027 Padded 420 rudder cover

EX3028 Padded 420 daggerboard cover



**SAIL FASTER 420 DVD**

Learn how to go faster on your 420 with the help of world champions. Here you can see some amazing and never seen action shootings of 420 sailing in Lagos, Portugal. Shot with an articulated steady-cam, underwater cam and an inside boat camera for you to see all the secrets. Featuring several worldchampions of the past years.

EX3030 Sail faster 420 DVD



**420 TRAINING SAILS**

International 420 main and jib of 4.18 Challenge performance Dacron.

Well finished including sailbattens class logo and tell-tales.

7 panel main and 6 panel jib. 7 panel spinnaker of 0.75 oz Challenge cloth

EX3035 420 Jib

EX3036 420 Main

EX3037 420 Spinnaker

EX3038 420 Main+ Jib (set)

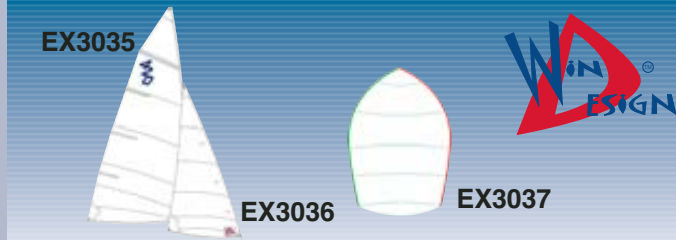

**420 SPINNAKER POLES**

38-25 mm tapered pole and 25 mm untapered pole both with Selden pole ends. With trip line and eye for uphaul.

EX3040 Untapered 420 spinnaker pole

EX3042 Tapered 420 spinnaker pole

EX3043 25 mm pole end

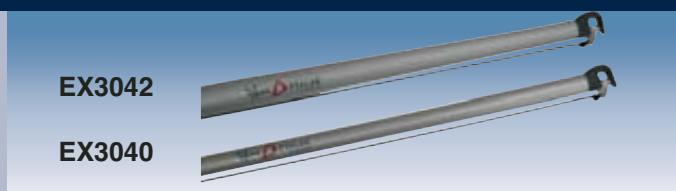

**OTHER ACCESOIRES**

The original 27 cm (10") Hawk Wind Indicator. Lightweight with a balanced arm and the Hawk "V" jewel bearing surface. Weight: 25 gms

EX3044 Original 10" hawk wind indicator

Two part trapeze handle. The 2 half's can be assembled around existing trapeze wires. No need to replace the complete wire in case a handle fails.

EX3045 Two part trapeze handle

Clamcleat CL253Trapeze and Vang Cleat, with integral roller and fairlead  
Material: Aluminum, Rope Range: 4-8mm

EX3055 Clamcleat CL253 Trapeze and Vang Cleat



**WOOD EPOXY 420 RACING FOILS**

Wood / Epoxy 420 racing centerboard and rudderblade. Perfect shape and very well finished.

Spruce finished with a 220 gr. roving and 150 gr. mat

High gloss finish.

EX3046 Wood / Epoxy 420 Racing rudderblade

EX3047 Wood / Epoxy 420 Racing centerboard

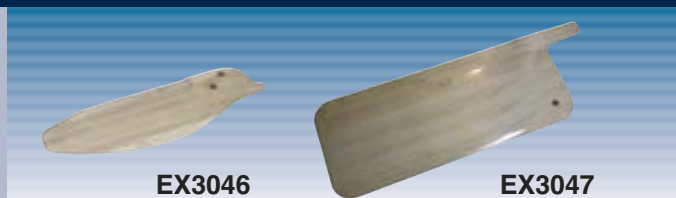

## TROLLEY FOR LASER®

Trolley for a Laser® based upon the same proven quick release system as used on our Optimist trolley.  
Made of square Aluminum tube with rounded corners.  
The frame has welded joints and is anodized to prevent corrosion.  
The bow locks into a horseshoe shaped padded support.  
Unlike other manufacturers we do not use a webbing sling to support the hull. The hull rests on 2 side supports which lock under the gunwale.  
In the middle the hull rests on a padded section of the frame. This provides a stable support. A sling stays wet and will increase the risk of osmosis.  
Spring locking (Quick release) allows the unit to be disassembled in a matter of seconds for storage and travel. Weight including wheels 11.5 kg

Spare parts can be found on page 4 of this catalog.

EX2015 Trolley / dolly for Laser®



## HIKING BENCH FOR LASER®

Fully detachable hiking bench. With adjustable hiking strap.  
2 padded supports. Perfect for that extra training session. Convenient portable and quick to assemble due to the quick link detachable joint design. Super strong but weighs just 5.7 kg.  
Designed by Laser® sailors.

EX2018 Hiking bench for Laser® or other dinghy sailors



## ADVANCED LASER® BOAT HANDLING DVD

Using different viewing angles, including coach, onboard and aerial cameras, Laser® sailors of any level can now follow the simple step by step images showing how to master maneuvers around the course.  
With over 50 minutes of meticulous analysis, pictures and slow motion clips from the hands of the Laser® Training Center head coach Javier Rulo Borojovich, you will learn all the tricks in no time. NTSC/English DVD.  
17 sailors who raced the 2008 Olympic Games, trained at the Laser® Training Center. See here the footage these top sailors used to get even better.

Tacks, Jibes, penalty turns, windward and leeward mark roundings performed by some of the best Laser® sailors in the world, are sliced into easy to follow segments.

EX3034 Advanced Laser® boat handling DVD

EX3034-10 Advanced Laser® boat handling DVD - 10 pack-

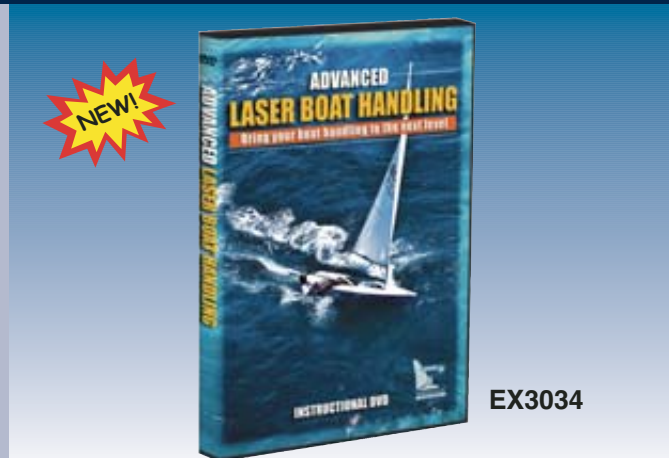

## BOAT WHISPER DVD SET

Learn the race winning secrets from Steve Cockerill.  
These DVD's show the upwind and downwind action with a comprehensive debrief and investigation of the footage, which enables Steve to communicate his unique perspective on sailing dinghies.  
Both experienced and inexperienced helms will find these informative DVD's helpful in improving their technique and understanding of boat handling.

EX3033 Boat Whisper DVD pack (pack of 2 upwind / downwind)

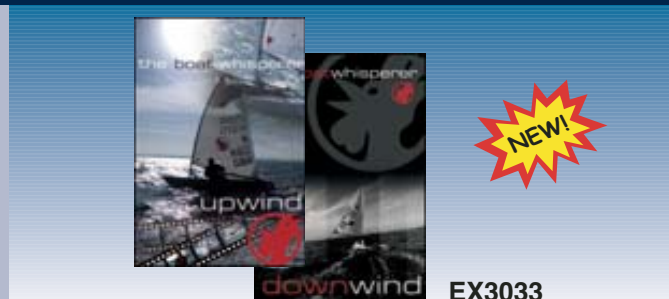

## PADDED HIKING STRAP FOR LASER®

Extra wide padded hiking strap. For comfortable hiking  
Black webbing, 75 mm wide partly covered with black wear resistant cloth filled with close-cell foam plate material. Does not absorb water.  
Loop on the aft and open on the front. Width: 10 cm, length: 76 cm

EX2000 Padded hiking strap

EX2002 Mounting plate

EX2004 Daggerboard friction plate



**TRAINING SAILS FOR LASER® AND LASER® PICO**

Training / School sail for the 4.7, radial and standard Laser®.  
Made of extra heavy 4.5 OZ white Dacron sailcloth.  
These sails have 6 panels and heavy duty reinforcements in the corners.  
Including sailbattens and sailbag. **\*Not allowed for official class racing.**

EX2023	Training/School sail for 4.7 Laser® *
EX2025	Training/School sail for radial Laser® *
EX2030	Training/School sail for standard Laser® *
EX2031	Set of sailbattens to fit all sails for Laser® (2x60 cm1x40 cm) *

Sail for Laser® Pico. This sail consists of a mainsail and jib made out of 4 OZ purple Dacron sailcloth. The jib incorporates a 3mm stainless steel forestay. Comes with a sailbag.

EX2035	Training/School sail for Laser® Pico. (Main + Jib) *
--------	--

**THESE SAILS ARE BUILT STRONG TO LAST LONG**

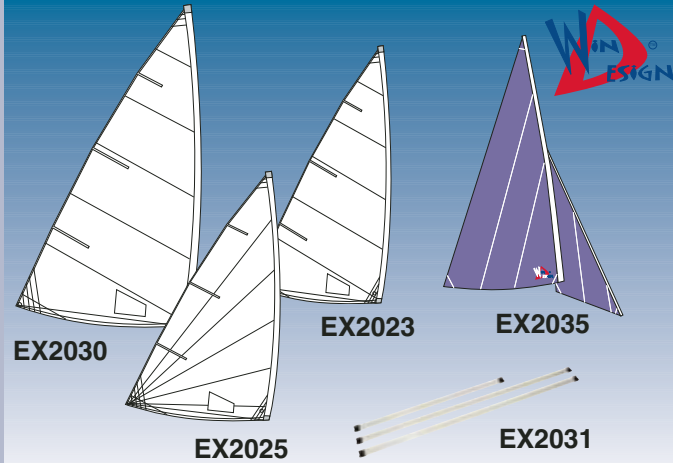

**REPLACEMENT SPARS FOR LASER®**

As good as the original, but: \* not allowed for official class racing.  
Bottom mast sections for 4.7, Radial and Standard. Top mast section and boom with original blocks and fittings.  
These spars make the perfect budget solution with the sails above.

EX2110	Replacement bottom mast for 4.7 Laser® *
EX2112	Replacement bottom mast for radial Laser® *
EX2114	Replacement bottom mast for standard Laser® *
EX2116	Replacement top mast for 4.7, radial and standard Laser® *
EX2118	Replacement boom for standard Laser® *

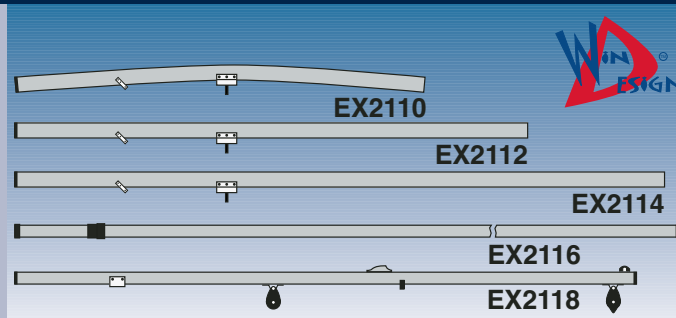

**SPAR AND HULL FITTINGS FOR LASER®**

EX2120	Bottom mast plug
EX2122	Bottom plug top mast
EX2124	Top plug top mast and outer boom end plug
EX2126	Top mast sleeve
EX2128	Boom inner end plug
EX2130	Gooseneck
EX2132	Vang mast attachment
EX2134	Vang boom attachment
EX2136	Clamcleat cl211 mk1 for outhaul and traveler, silver coated
EX2137	Clamcleat cl211 mk1 for outhaul and traveler, hard anodized
EX2138	Eyelet for outhaul and traveler
EX2139	Bow Eye
EX2140	Eyelet for mainsheet blocks
EX2142	Vang block block
EX2144	Vang block with jam
EX2146	Vang key straight
EX2148	Vang swivel
EX2150	Mainsheet block
EX2152	Mainsheet block with sister hook
EX2154	Mainsheet block with becket
EX2156	Traveler block with sister hook

Teflon mast disk. Drop it into the mast hole. It absorbs grit and creates less friction between the bottom of the mast and the maststep.

EX2160 Teflon mast disk  
Do not use sticky duck tape anymore but apply a piece of heat shrinkable tubing around the joints of the blocks. Best applied with a heat gun.  
Large enough to slide over the smallest block before shrinking.

EX2161 Shrink tube for Laser® traveler blocks, 10 pcs  
Soft eyestay kit. This kit contains webbing and rivet with washer to mount this soft eyestay. Class rules let you replace the stock stainless steel lacing eyestay in the middle of your boom with this soft strap.

EX2164	Soft eyestay kit *
--------	--------------------



## COVERS AND BAGS FOR LASER®

Top quality, long-life top and bottomcovers from Moistureguard 2000. Moistureguard 2000, is a heavy duty 900D breathable polyester with a polyurethane membrane. Moistureguard reduces the risk of blisters. The topcover is slightly tented so that spars can be stored inside the boat and has wide skirts around the edge of the hull to provide good protection. This cover is easy to install and has 3 straps with adjustable buckles. The bottomcover has webbing loops are installed to be able to pull the cover tight around the hull during transport.

EX2040	Breathable topcover Color: Light grey
EX2045	Breathable undercover Color: Light grey
Economy topcover of super strong 1680D pvc /polyester and economy bottomcover of 600D pu coated polyester. Shape like the covers above	
EX2041	Economy topcover. Color: Light grey, Blue skirt.
EX2044	Economy bottomcover. Color: Light grey

Heavily padded envelope style **BLADEBAG**. Separate compartments for rudder, daggerboard, tiller and a large pocket for accessories. The rudder and daggerboard compartments have a Velcro closure over the full length. With carrying handle and adjustable and detachable strap.

EX2050 Rudder/daggerboard bag for Laser®, Europe, Splash etc.



## ROOSTER ROPE MAINSHEET

The rope has a light high stretch inner core which leaves the outer core to be the load bearer. This unique design helps to maintain stability and prevents the rope from tangling. Diameter: 7 mm

EX2058	Rooster rope mainsheet for Laser®, length 13.5 m (44 ft)
EX2060BL	Rooster rope 200 m (656 ft) reel. Blue
EX2060BK	Rooster rope 200 m (656 ft) reel. Black



## OUTHHAUL AND CUNNINGHAM UPGRADE

A low cost solution for upgrading old Laser® hulls to a new outhaul and cunningham system. The angled base has the same mounting holes, and the wide angled fairlead and keeper gives this cleating system the same feel, like the original one. Unfortunately this is not a builder supplied cleat and therefore not allowed for racing in ILca sponsored events. With no moving parts this setup will outlast the cam cleats with the additional advantage that the keeper will not allow accidental cleating or releasing.

Stainless steel double pad eye for outhaul and cunningham upgrade. Supplied with 2 Harken micro blocks as pictured.

**\*Not allowed for official class racing.**

EX2175	Cunningham upgrade cleat assembly *
EX2178	double pad eye with 2 Harken micro blocks *
EX1334	Harken micro block



## CLEW STRAP, CLEW HOOK AND CLEW SLEEVE

The ultimate clew tie down system for the Laser®. One end of the strap has the loop velcro on both sides. It then sandwiches between the hook velcro, providing so much contact area that the strap will not slip. A piece of hard material reduces friction between the webbing and the boom. Can be used with a clew hook, with or without Harken airblock, to create a quick easy and reliable clew system.

EX2005	Clew strap
EX2007	Clew hook
EX2008	Clew hook with 16 mm Harken airblock

New for 2009. Windesign clew sleeve. The stainless steel sleeve will be fixed to the boom and does not have to be detached after sailing. The quickest system for fixing the clew.

**\*Not allowed for official class racing.**

EX2010 Clew sleeve with 16 mm Harken airblock \*



## FOILS FOR LASER®

Rudderhead and gudgeons for Laser®.

The cheeks are silver anodized and the head can be used with the rudderblade and tillers below. \*Not allowed for racing.

EX2051	Gudgeon for Laser®
EX2052	Heavy duty 10 mm pivot bolt *
EX2053	Rudderhead for Laser® *

Wood core with fiberglass laminate and white gelcoat.

These foils are not allowed for racing but are perfect for replacing the original foils which came with your boat. \*Not allowed for racing.

EX2054	Rudderblade for Laser® *
EX2055	Centerboard for Laser® *

EX2056	Rudder retaining clip
EX2057	Tiller retaining pin *

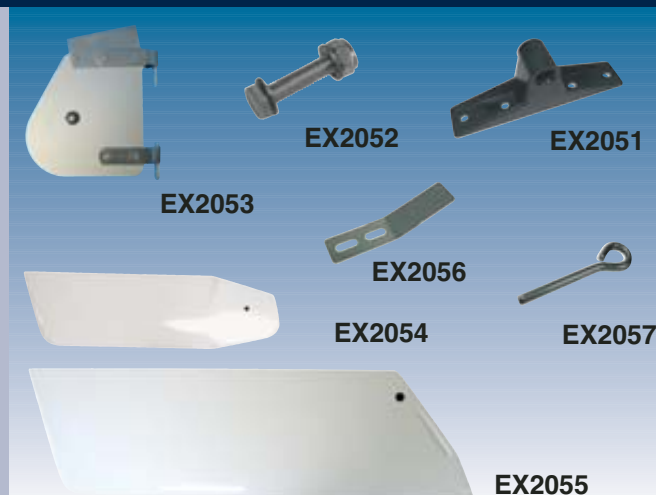

## BAILER AND DRAIN PLUG FOR LASER®

Complete autobailer for Laser®. Can be used as a replacement bailer but is not legal for racing. Including cockpit plug, screw and plug for the hull.

EX2070	Auto bailer for Laser® *
EX2072	Replacement kit, two O-rings, a chute and a cockpit plug.*
EX2074-10	Replacement O-rings, set of 10 *
EX2076	Cockpit plug.*

EX2080	Drain plug assembly
EX2081	Drain plug only



## HAWK MK2 WIND INDICATOR

Lightweight nylon vane arm pivoting on a 4 mm Aluminum pin.

With clip to mount on any mast with a diameter between 45 and 65 mm.

EX2020	HAWK MK2 wind indicator.
--------	--------------------------



## RIG SUPPORT FOR LASER®

High grade plastic molded rig support for standard Laser®. The front piece fits in the masthole and the back molding fits between the deck.

The spars are fixed to the supports with shockcord.

Boom, top and bottom mast can be quickly and easily stored without damaging the deck during transport.

EX2065	Rig support for laser®.
--------	-------------------------



## TILLERS FOR LASER®

CARBON tiller for Laser®. Same design as our 2007 tiller but stiffer and better finished. Now with new stainless anti chafe plate which goes around the edge of the tiller. The low profile, high stiffness and low weight creates an amazing light feeling when steering the boat.

652112	120 cm 20 mm carbon tiller extension with detachable joint
652850	Carbon tiller for Laser®.

The famous 32 mm Aluminum tiller with Larry Marks end casting. The tiller comes in a Deluxe and a Standard version.

The Deluxe version is 25 microns black anodized and has a stainless steel anti-chafe protecting plate for the traveler line. An Aluminum clamcleat for the rudderblade line is mounted on the side of the tube.

The standard tiller is silver anodized and has no chafe plate and no cleat.

652900	Deluxe tiller for Laser® excluding extension.
652910	Deluxe tiller for Laser® including extension 652310.
652930	Standard tiller for Laser®.



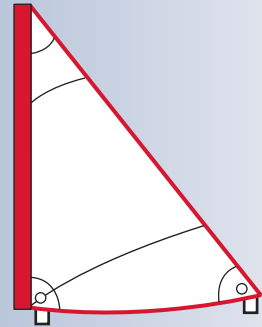

**For 2010 :**

DVD's for Laser® sailors

Racing rules dvd

Windesign block

TRI sail

Corner protectors

Solid rubber wheel

Optimist model

Outhaul and cunningham upgrade

Hiking bench for dinghy sailors

420 daggerboard bag

Roller gear bag



Ask for genuine **OPTIPARTS**® and **WINDESIGN**® at :

